



2BTUBE CONTROLLER



Diagnostic LED

The ASI 2BTube motor controller utilizes the latest in sinusoidal flux vector control to ensure smooth and quiet brushless DC motor operation and efficient vehicle operation. They can operate over a nominal battery voltage range of 24VDC to 48VDC.

A robust MOSFET-based three phase bridge provides peak efficiencies in excess of 99%, with no audible noise. Hall sensor based motor commutation, and sensorless commutation are also supported.

Programmable performance mapping allows throttle and regenerative braking inputs to be adjusted via ASI's BACDoor™ PC configuration/Engineering software to meet specific performance requirements.

Numerous programmable protection features including motor/controller temperature, battery over/under voltage, and motor/battery current limits increase controller and motor longevity.

Intelligent. Configurable. Reliable. Powerful.

- Can be attached to additional heat sinking to significantly increase performance
- PWM drive for low ripple current and silent drive
- Field oriented control for increased efficiency and smooth motor operation
- Multiple analog and digital inputs
- CANOpen & TTL communication
- Support multiple sensor configurations
- Single pulse and quadrature pedal or wheel speed inputs
- Analog voltage model or BMS communication based battery management system interfaces
- Sensorless or hall commutation with automatic switching
- Configurable throttle, brake cut-off and regeneration options
- Fault protection including:
 - Bus over and under voltage
 - Motor over current
 - Motor and controller over temperature
 - MOSFET bridge self tests
 - Battery SOC foldback

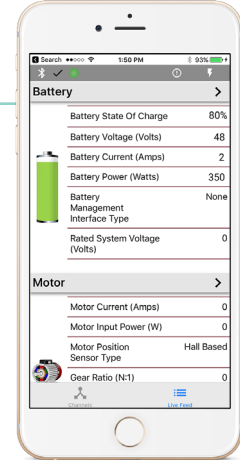

Includes BACDoor software to fine tune performance. Available for OEM customers.



Engineered in Canada

SPECIFICATIONS

OUTPUT PHASE CURRENT CONTROLLER	
CONTROLLER	PEAK
2BTUBE	50 A

INPUT POWER	
CONTROLLER	VOLTAGE RANGE (DC)
2BTUBE	24V to 48V

COMMUNICATION PROTOCOL	
TTL-232-CANOpen	Standard
TTL-232 with TTL-232	Optional

CONTROLLER POWER AND PERFORMANCE	
PWM frequency	13 kHz default / up to 16.5 kHz when operating in remote mode
Maximum Controller output frequency	500 Hz
Electrical isolation to heatsink	500 VAC
Storage ambient temperature	-35°C to 75°C
Operating ambient temperature	-20°C to 50°C
Thermal cutback	Controller linearly reduces maximum current limit with an internal heatsink temperature from 80°C to 95°C, complete cutoff occurs above 95°C
Package environmental rating	IPX6 (with all mating connectors connected)
Speed regulation (range)	+/- 5% at top speed
Minimum motor phase to phase inductance	20 µH
Motor control scheme	Sinusoidal field oriented (FOC)
Motors supported	PMAC and BLDC

INPUT SPECIFICATIONS				
TYPE	QTY	VOLTAGE	VMIN	VMAX
Hall sensor inputs	3	Logic Low	0 VDC	0.5 VDC
		Logic High	3.5 VDC	5 VDC
Digital inputs	2	Logic Low	0 VDC	0.5 VDC
		Logic High	3.5 VDC	5 VDC
5V analog inputs	3	Analog	0 VDC	5.5 VDC
10V analog inputs	1	Analog	0 VDC	10.5 VDC

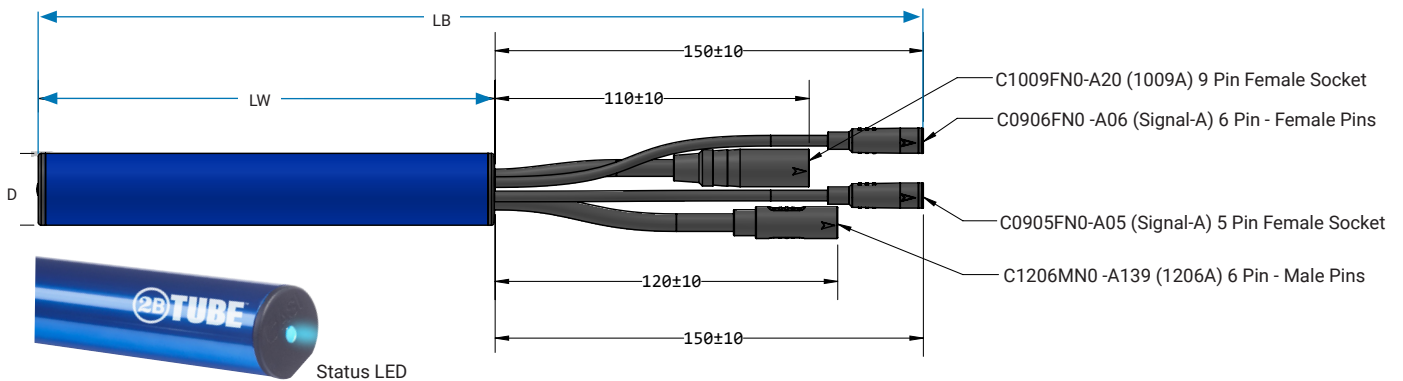

DIMENSIONS* & WEIGHT								
MODEL	LW (BODY)		LB (W/WIRES)		DIAMETER		WEIGHT	
	mm	in	mm	in	mm	in	g	lb
2BTUBE	161	6.34	Various		24.9	.98	195	.43

*Measurements are +/- 10mm or .40 in



519.342.2507 | www.acceleratedsystems.com

PIN OUT TABLE

9 PIN CUSMADE FEMALE CONNECTOR C1009FN0-A20 (1009A)

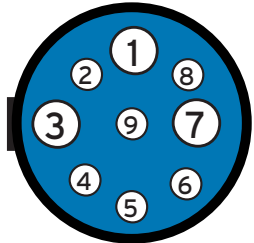
PIN #	COLOR	FUNCTION	FUNCTION (CLASSIC)	SPECIFICATIONS & RATINGS	MOTOR
1	Blue (Thick)	Phase C	Phase C	29A peak	
2	White	Analog Input 3	Brake 2	0-5V (pulled up). Used for Temperature Signal	
3	Yellow (Thick)	Phase B	Phase B	29A Continuous Peak RMS (Connector Limited)	
4	Red	Hall 5V Output	Hall 5V Output	20mA max	
5	Blue	Hall C	Hall C	0V ON, 5V OFF	
6	Yellow	Hall B	Hall B	0V ON, 5V OFF	
7	Green (Thick)	Phase A	Phase A	29A Peak	
8	Green	Hall A	Hall A	0V ON, 5V OFF	
9	Black	Hall GND	Hall GND	20mA max	

Mating Connector- Cusmade C1009MN0-A20 (1009A) 9 Pin Male

6 PIN CUSMADE FEMALE CONNECTOR C0906FN0-A06 (SIGNAL-A)

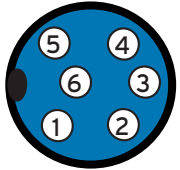
PIN #	COLOR	FUNCTION	FUNCTION (CLASSIC)	SPECIFICATIONS & RATINGS	SENSOR
1	Orange	5V Output	5V Output	50mA max	
2	White	Digital Input 1	Cruise	Pulled up, active low	
3	Brown	Analog Input 1	Throttle	0-5V (pulled down)	
4	Green	Analog Input 2	Brake 1	0-5V (pulled up)	
5	Black	GND	GND	100mA max (shared between all GND's)	
6	Purple	Digital Input 2	PFS	Pulled up, active low	

Mating Connector- Cusmade C0906MN0-A06 (Signal A) 6 Socket Male

5 PIN CUSMADE FEMALE CONNECTOR C0905FN0-A05 (SIGNAL-A)

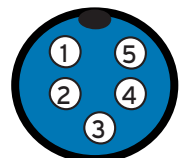
PIN #	COLOR	FUNCTION	FUNCTION (CLASSIC)	SPECIFICATIONS & RATINGS	DISPLAY
1	Orange	B+ Output	Key-out	Always live connected to Controller B+	
2	White	Controller enable Input	Key-in	May draw up to 100mA	
3	Brown	CAN-H	CAN-H	Configurable 120Ω termination resistor	
4	Green	CAN-L	CAN-L	Configurable 120Ω termination resistor	
5	Black	GND	GND	100mA max (shared between all GND's)	

Mating Connector- Cusmade C0905MN-A05 (Signal A) 5 Pin Male

6 PIN CUSMADE MALE CONNECTOR C1206MN0-A139 (1206A)

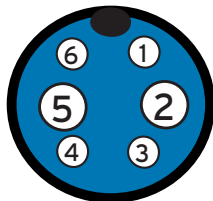
PIN #	COLOR	FUNCTION	FUNCTION (CLASSIC)	SPECIFICATIONS & RATINGS	BATTERY
1	Blue	TTL-Tx	TTL-Tx	5V TTL, 6V max	
2	Black (Thick)	Battery -	Battery -	19.5A max	
3	Orange	CAN-H	CAN-H	Configurable 120Ω termination resistor	
4	Brown	TTL-Rx	TTL-Rx	5V TTL, 6V max	
5	Red (Thick)	Battery +	Battery +	19.5A max	
6	Grey	CAN-L	CAN-L	Configurable 120Ω termination resistor	

Mating Connector- Cusmade C1206FN0-A139 (1206A) 6 Socket Female



519.342.2507 | www.acceleratedsystems.com