



# HIGH POWER CONTROLLERS

BAC2000 | BAC4000 | BAC8000



## ***DELIVERING DISTINCTION***

As a key part of the ASI electrification eco-system, our family of High Power controllers provide the platform to seamlessly engineer the safe, power efficient vehicle feel that is synonymous with your brand. Paired with SAGE, our AI driven Vehicle Control Module, and BACDoor,<sup>™</sup> our sophisticated engineering software, OEMs can rapidly, with minimal effort, bring to market diverse power equipment products.

### **Benchmark Features**

*Unrivaled levels of customization*

*CANOpen with optional Bluetooth*

*Efficient full-torque control at zero RPM*

***Sharing a common evolutionary origin, our motors, controllers and VCM deliver the platform to build your product roadmap vision.***

***If you can imagine it, ASI's electrification ecosystem can realize it.***



**Engineered in Canada**

519.342.2507 | [www.acceleratedsystems.com](http://www.acceleratedsystems.com)

10.2021 © Accelerated Systems Inc.

# DELIVERING DISTINCTION



## POWERFUL

More torque for your low-voltage applications.



## CUSTOMIZABLE

Second to none customization; engineer the performance synonymous with your distinct brand.



## ROBUST

IP rated for outdoor use and harsh industrial environments.



## ADAPTABLE

Supports variety of motor types, I/O's and communication protocols. Standalone controller or as part of network.

<b>Open Architecture Software with Read/Write Capabilities</b>	We empower customers with the autonomy to customize and manipulate the parameters of the controller to achieve your unique vehicle over UART or CANOpen.	<b>Unparalleled Sales Support</b>	Our application engineering team will work with you in real-time to create a unique product for your target customer base.
<b>Halls and Sensorless Motors</b>	Ultimate freedom in motor choice. Hall based motors provide smooth engagement. Sensorless motors provide better efficiency. Hall start and sensorless run for the best of both worlds in either geared or direct drive motors.	<b>BACDoor™ Engineering Software</b>	Complimenting ASI's series of peerless High Power controllers is BACDoor™. Proprietary software enabling OEMs the ultimate experience in performance customization and diagnostics.
<b>Sine Wave FOC Controller</b>	Our proprietary algorithms take this industry standard to even greater levels of smoothness and quietness. Unfluctuating, smooth feel while also being whisper quiet.	<b>Local or Remote Command Modes</b>	Commanding motor operation via local inputs or remotely over a network.
<b>Portable Technology</b>	Our software is fully portable. In addition, it can drive multiple power equipment products, so you can benefit from standardizing on a single supplier without needing to re-learn software.	<b>Choice of 3 Different Control Modes</b>	Choice of speed, torque, or hybrid (torque with speed limiting) motor control; choose what is best for your application.
		<b>Fault Protection and Foldbacks</b>	Fault protections reduce and avoid dangerous component or system-level failures. Foldbacks protect the system by reducing power output in a controlled manner to reduce component damages.

# TECHNICAL SPECIFICATIONS

HARDWARE # 10-000841, 10-000842, 10-000843

	BAC2000	BAC4000	BAC8000
Nominal input voltage	36 V to 72 V		
Recommended lower voltage limit	30 V		
Absolute maximum operating voltage	86 V		
Battery current consumption	Off = 0 A Idle < 0.1 A Max (est.) = 185 A	Off = 0 A Idle < 0.1 A Max (est.) = 395 A	Off = 0 A Idle < 0.1 A Max (est.) = 730 A
Peak phase current	200 A	430 A	840 A
Peak Efficiency	95% or greater		
FET PWM switching frequency range	10 kHz to 17 kHz (application and firmware dependant)		
Maximum recommended motor electrical frequency	10 % of switching frequency		
Minimum recommended motor phase to phase inductance	20 µH		
Supported motor types	3-Phase surface permanent magnet motors.		
Supported motor position sensor types	For other 3-phase motor types, contact ASI Application Engineering & Technical Support for more information.		
Input capacitance	1.64 mF	2.01mF	4.22 mF
Operating ambient temperature range	-20 °C to 50 °C		
Storage temperature range	-35 °C to 85 °C		
Thermal cutback	The controller linearly reduces maximum output current when the internal controller temperature is above 80°C. Complete cutoff occurs at 100°C, the control board over-temperature threshold.		
Ingress protection	IPX5 with fully populated connectors		
Communication protocols & qty	<b>Standard:</b> 1x ASI CANopen, 1x TTL-232, <b>Optional:</b> 1x Bluetooth Low Energy		
Dielectric withstand production test	< 2mA at 300VAC, minimum		

## INPUT SPECIFICATIONS

TYPE	QUANTITY	LOGIC			ELECTRICAL LIMITS	
		TYPE	Vin.min	Vin.max	PEAK CURRENT	TRANSIENT VOLTAGE
Digital 5 V, pulled-up, active low – Halls	3	Vin.low	n/a	1.2 V	n/a	90 V
		Vin.high	2.5 V	n/a	n/a	90 V
Digital 5 V, pulled-up, active low – Peripherals	2	Vin.low	n/a	3.6 V	n/a	90V
		Vin.high	4.6 V	n/a	n/a	90V
0-5 V analogue, configurable pull-up	2	Vin.high	n/a	5.3 V	n/a	n/a
0-5 V analogue, pulled-down	1	Vin.high	n/a	5.3 V	n/a	n/a
0-10 V analogue, pulled-down	1	Vin.high	n/a	11 V	n/a	n/a
Key-in	1	VBat+	30 V	86 V	Not limited	90 V
CAN	1	5V	n/a	n/a	n/a	+58V
TTL	1	5V	n/a	n/a	n/a	90 V
Battery	1	Battery Positive, (VBat+)	30 V	86 V	Not limited	90V
	1	Battery Positive, (VBat-)	n/a	n/a	Not limited	n/a
	1	Hall Ground	n/a	n/a	100 mA	n/a
	2	Signal Ground	n/a	n/a	400 mA shared	n/a

- All specifications are for an ambient temperature of +25°C, unless otherwise specified are subject to change without notice
- This specification sheet supersedes: asi\_high\_power\_controllers\_spec\_sheet\_w\_pin\_out\_table.pdf rev3.9, 01/2021

# OUTPUT SPECIFICATIONS

TYPE	QUANTITY	NOMINAL OUTPUT	ELECTRICAL LIMITS	
			Current	Transient Voltage
Hall 5V output	1	5 V	100 mA	47.5 V
5V output	2	5 V	50 mA Shared	n/a
12V output	1	12 V	50 mA	47.5 V
Low side switch	1	0 V	100 mA	57 V
Phases	3	VBat+	Not limited	90 V

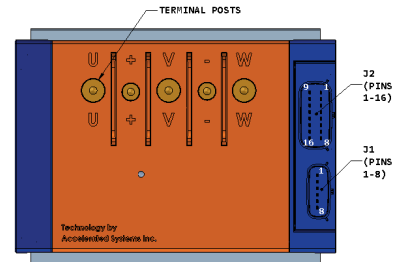

## BAC2000 | BAC4000 | BAC8000 PIN-OUT

### MX150 6 PIN DUAL ROW FEMALE CONNECTOR, MOLEX P/N 33471-0601

PIN	FUNCTION	ELECTRICAL LIMITS		SPECIFICATIONS
		Current	Transient Voltage	
1	Hall 5V output	100 mA	47.5 V	
2	Hall Ground	100 mA	n/a	
3	Hall A input	n/a	90 V	Digital 5 V, pulled-up, active low
4	Hall B input	n/a	90 V	Digital 5 V, pulled-up, active low
5	Hall C input	n/a	90 V	Digital 5 V, pulled-up, active low
6	Analog input 3	n/a	n/a	Brake 2" or "Motor temperature sensor" 0-5 V Analogue, configurable pull-up

### MX150 16 PIN DUAL ROW FEMALE CONNECTOR, MOLEX P/N 33472-1601

PIN	FUNCTION	ELECTRICAL LIMITS		SPECIFICATIONS
		Current	Transient Voltage	
1	Low side switch	100 mA	57 V	"HDQ"
2	Digital input 1	n/a	90 V	"Cruise" Digital 5 V, pulled-up, active low
3	TTL-Tx	n/a	90 V	5 V TTL
4	5V output	50 mA	n/a	50 mA Shared with all 5 V output
5	Digital input 2	n/a	90 V	"PFS" Digital 5 V, pulled-up, active low
6	Analog input 2	n/a	n/a	"Brake 1" 0-5 V Analogue, configurable pull-up
7	Analog input 1	n/a	n/a	"Throttle" 0-5 V analogue, pulled-down
8	5V output	50 mA	n/a	50 mA Shared with all 5 V output
9	Key-in	Not limited	90 V	Requires B+
10	CAN-L	n/a	±58 V	5 V Software configurable 120 Ω termination resistor
11	CAN-H	n/a	±58 V	5 V Software configurable 120 Ω termination resistor
12	Analog input 4	n/a	n/a	"ABMS" 0-10 V analogue, pulled-down
13	TTL-Rx	n/a	90 V	5 V TTL
14	Signal ground	400 mA	n/a	400 mA Shared with all <i>Signal ground</i>
15	Signal ground	400 mA	n/a	400 mA Shared with all <i>Signal ground</i>
16	12V output	50 mA	47.5 V	

- All specifications are for an ambient temperature of +25°C, unless otherwise specified are subject to change without notice
- This specification sheet supersedes: asi\_high\_power\_controllers\_spec\_sheet\_w\_pin\_out\_table.pdf rev3.9, 01/2021

# TERMINAL POSTS

TERMINAL	FUNCTION	ELECTRICAL LIMITS		TERMINAL THREAD & TORQUE SPECIFICATIONS	
		Peak Current	Transient Voltage	BAC2000 BAC4000	BAC8000
U	Phase U/A	Not limited	90 V	M5x0.8 – 16mm Up to 6 N-m torque, dry	M6x1.0 – 12mm Up to 8 N-m torque, dry
+	VBat+	Not limited	90 V		
V	Phase V/B	Not limited	90 V		
-	VBat-	Not limited	90 V		
W	Phase W/C	Not limited	90 V		

# DIMENSIONS AND WEIGHT

PRODUCT	L [MM]	W1 [MM]	W2 [MM]	H1 [MM]	H2 [MM]	WEIGHT [KG]
BAC2000	125	126	114.4	49	39.5	1.02
BAC4000	173	126	114.4	51	39.5	1.43
BAC8000	246	126	114.4	52	39.5	2.05

# OVERALL DIMENSIONS

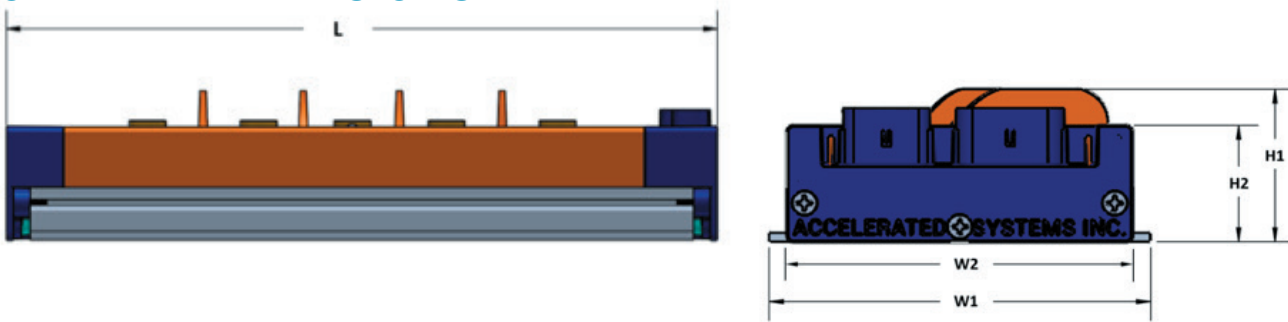

- All specifications are for an ambient temperature of +25°C, unless otherwise specified are subject to change without notice
- This specification sheet supersedes: asi\_high\_power\_controllers\_spec\_sheet\_w\_pin\_out\_table.pdf rev3.9, 01/2021